

150W 3IN1 Beam,Spot,Wash LED Moving Head KA-150BSW

Main Feature

KA-150BSW seamlessly integrates light beam, dyeing and pattern effects with mature and stable design of various performances. It has a variety of color discs, pattern discs, flexible straight-line mirrors and prisms supplemented by a variety of stroboscopic speeds, to create a gradient magic light effect. The beam angle can be switched at will according to different needs, combined with an independent fog environment to create different rendering effects. LED-150BSW integrates multiple functions and effects, making it an ideal choice for lamps in the entertainment market.

Specifications

Beam Angle: 11° (on full open) 2°/4°/6°/8°/10° (with beam reducer) 3°/6°/9°/12°/15°/19° (with zoom lens)

Spot Angle: Fix Gobo: 10°~15° (with zoom lens)

Rotating Gobo: 10°~17° (with zoom lens)

Wash Angle: 15°~28°

Control

DMX Channel: 17,20 channels

Control Mode: DMX, Master/Slave, Sound Active, RDM

Firmware Upgrade: Update via DMX link

Pan/Tilt

Pan/Tilt: 540°/270°

X-axis/y-axis precision: 16 bit precision scanning, magnetic positioning system, which can accurately and automatically correct the x-axis and y-axis positions

Display: LED color + 4 buttons touch key

Power in/out: PowerCon in & out

Protection Rating: IP20

Motorized focus

Color Wheel: 8 fixed colors plus white rainbow effect

Fixed Gobo Wheel: 1 static gobo wheel with 7 gobos plus open

Rotation gobo wheel: 1 rotating gobo wheel with 6 gobos plus open

Prism: 3 facets prism rotating in both direction

Gobo's outside diameter: 23.8mm Gobo's image diameter: 20mm

Outstanding color macro effect

0~100% smooth dimming Independent frost effect Various strobe speeds Integrated three features: beam, spot, and wash

Electrical and Physical

Input power: AC 100 ~240V, 50/60Hz

Power: 220W

Master Box size: 385x320x475mm

Gross Weight: 14kg

Flycase 2 in 1: 690x380x630mm

Gross Weight: 45kg

Flycase 4 in 1: 845x590x640mm

Included Items

User Manual

Power Cable

1x Fast-locked clamps



Photometrics Diagram

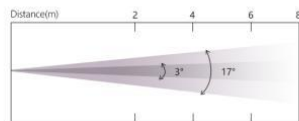

	3° Lux	3700	2300	1160
Diameter(m)	0.21	0.31	0.41	0.52
17° Lux	10500	2400	800	320
Diameter(m)	0.70	1.3	1.9	2.5



Renderings



Size mm(in)

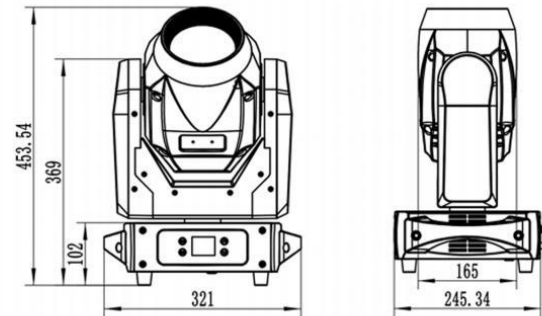

Functional Effect

Color Wheel



Static Gobo Wheel



Rotating Gobo Wheel



Multi-angle product diagram

